

Backlight Replacement Guide

Thank you for purchasing the FP790T-BL00 replacement backlight. Be sure to read the following Backlight Replacement Warnings prior to replacing your FP's backlight.

This replacement backlight package contains the following:

FP Model Name	Backlight Model
FP790T Series	FP790T-BL00

If this backlight is not appropriate for your FP or does not function correctly, please contact your local authorized FP representative.

WARNINGS

- Be sure the FP's power cord has been disconnected prior to changing the backlight. When the FP's power cord is connected and the FP is ON, high voltage runs through the wires in the backlight area - Do not touch any of this area's parts!
- When the FP's power cord has just been disconnected, the backlight area is still very hot! Be sure to wear gloves to prevent being burned.
- The backlight is very fragile. Do not touch the glass tube directly or try to remove its power cord. If the glass tube breaks you may be injured.



- *Be sure to change the entire backlight unit, i.e. both the tube and holder.*
- *Do not allow water, oil or fingerprints to remain on the tube, since they can all reduce the backlight's life.*

◆ Package Contents

- Two (2) Replacement Backlights (for upper and lower)
(Model:FP790T-BL00)

◆ Items Required When Changing The FP's Backlight

- Phillips screwdriver (no. 2) for FP's cover attachment screws.
- One pair of clean (preferably new) cotton gloves.
- A small container for the removed attachment screws to prevent them from becoming lost or misplaced.



■ Backlight Replacement

Use the following steps to change the backlight.



- ***During backlight replacement, be sure to protect the front surface of the FP's display so that it is not scratched or damaged.***
- ***The FP has both an upper and a lower backlight bulb. Be sure to replace both at the same time.***
- ***Since CFL is used for the backlights, they should be disposed of in a manner appropriate to your local government's laws or regulations.***

◆ Removing the Backlights

Replace the backlight according to the following procedure. (The following explanation assumes that the FP has already been removed from its operation panel)

- 1) **Place the FP on a flat worktable with the front panel facing down.**
- 2) **Loosen the nine (9) rear cover attachment screws, and remove the rear cover.**

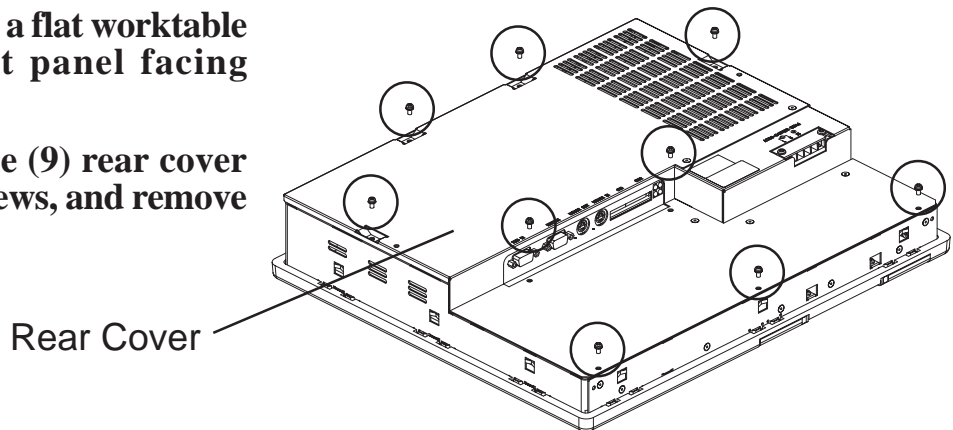

Since the attachment screws are small, be sure not to lose them or allow them to fall inside the FP's case.

- 3) **Remove the three (3) inner unit attachment screws.**

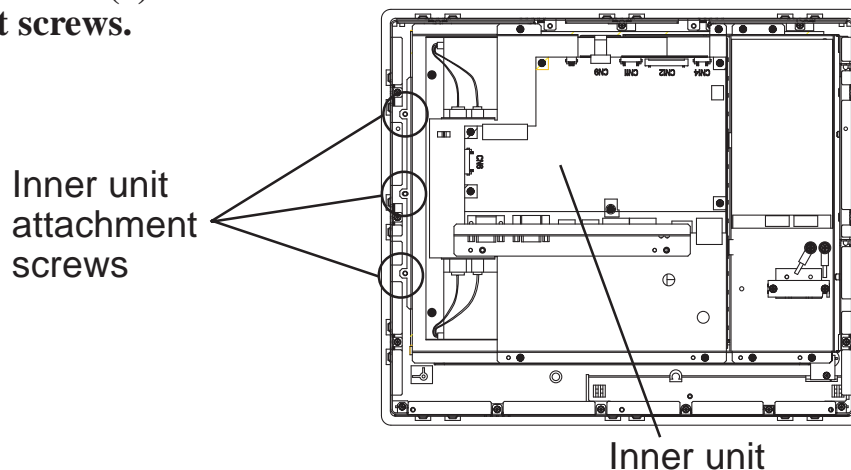

- 4) Free the backlight power cables from the cable clamps, and detach the four (4) backlight power connectors that connect the backlights to the inverter.

Backlight Power Connectors

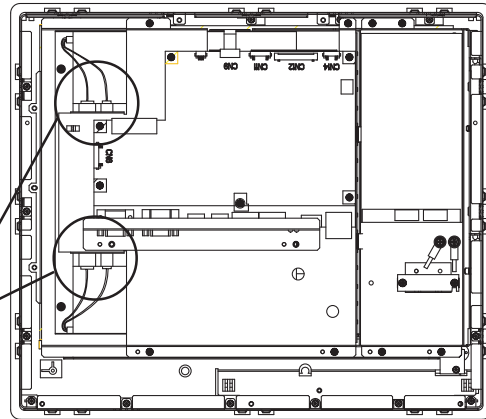

- 5) Lift up and hold one side of the inner unit (left or right).

Lift up the inner unit

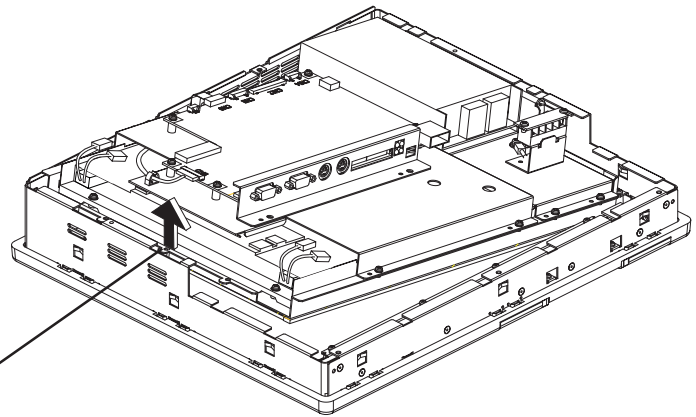

- 6) Carefully bend each backlight's Positioning Tab upwards until it is clear of the Positioning Pin. Then, slowly pull out each backlight horizontally from its holder.

Positioning Tab

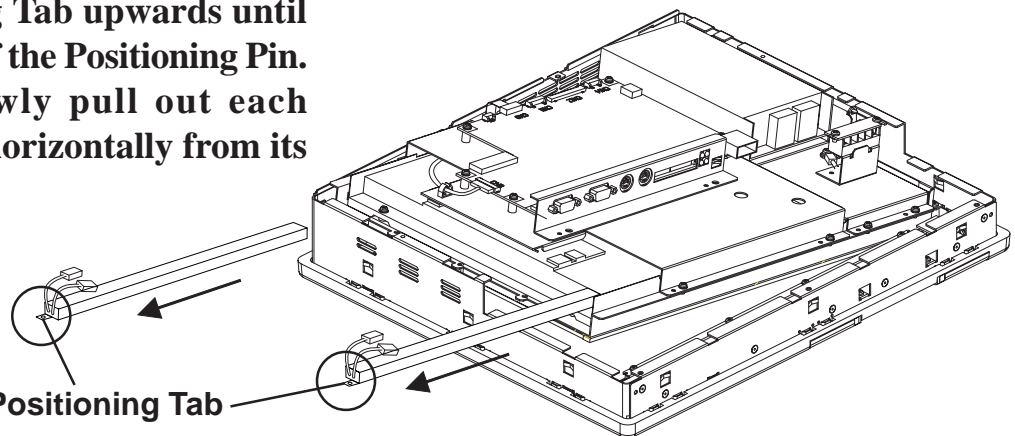

- ***Be sure to pull out the backlights gently if they are caught in their holders, or they can be damaged.***
- ***When pulling out the backlight and holding the Positioning Tab, be sure not to cut or pinch your fingers.***

◆ Attaching the Replacement Backlights

- 1) Insert each replacement backlight completely into its holder, until the Positioning Tab's hole is over the Positioning Pin.

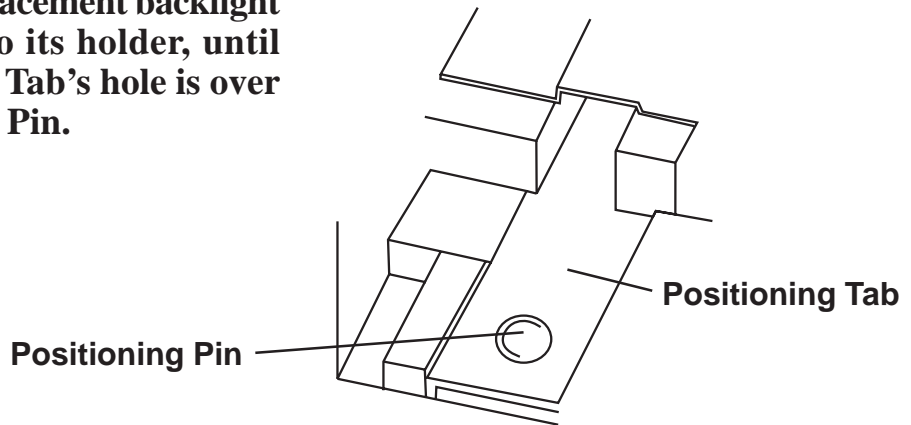

- **Each backlight package contains an upper and a lower backlight. Be sure to insert each backlight into the correct holder.**
- **When inserting the backlight into its holder, be careful not to cut or pinch your fingers on the Positioning Tab's edges.**

- 2) Secure each backlight cable in place by inserting it into its Cable Clamp.

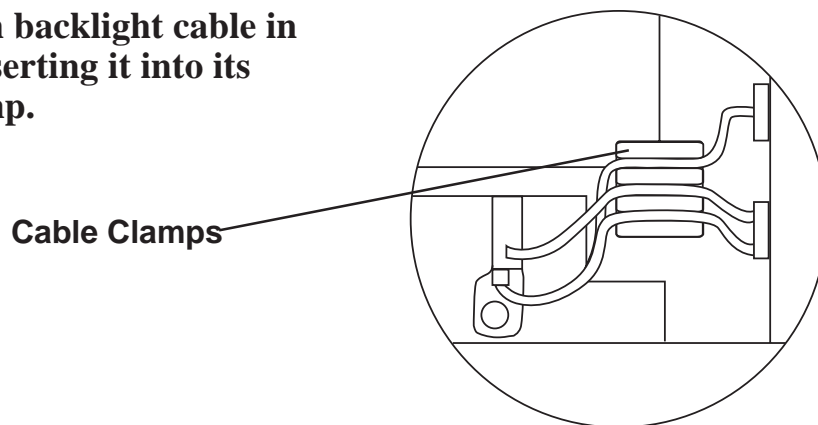

- 3) Connect all four (4) backlight power connectors.
- 4) Replace all three (3) inner unit attachment screws to secure the inner unit in place.
- 5) Reattach the rear cover, and replace the nine (9) rear cover attachment screws.



- **Be sure not to pinch or cut any of the FP unit's internal wiring when closing the rear cover.**
- **If any of the attachment screws becomes misplaced, check to be sure that they have not fallen inside the FP. If a screw has fallen inside the FP, do not connect the FP unit's power cord until the screw has been removed.**

After changing the backlight, be sure to check that your FP display operates correctly. If a problem occurs, contact your local FP distributor.
